

## 89 Dual Media Tank Water Filter Manual

**1. This manual contains important safety and operating instructions. Read all instructions and follow them when using this product. Failure to consider this information and follow these instructions, including those concerning maintenance, may result in property damage, injury and or death.**

**Page 23 of this manual contains important maintenance procedures for the continued proper operation of your unit. These MUST be performed regularly for your warranty to remain valid.**

- 2. We recommend installation only be completed by a competent installer or plumbing professional to insure this product is installed in accordance with local plumbing codes.**
- 3. Read this manual in full and follow all instructions carefully before operation.**
- 4. Avoid pinched O-rings during installation by applying NSF certified lubricant to all seals (provided with install kit).**
- 5. This system is not intended for treating water that is microbiologically unsafe or of unknown quality without adequate disinfection before or after the system.**
- 6. Discard small parts remaining after the installation.**
- 7. Failure to install the system correctly voids the warranty.**
- 8. Handle all components of the system with care. Do not drop, drag or turn components upside down.**
- 9. Save these instructions and keep track of your product's serial number.**

**NOTICE: THIS MANUAL CONTAINS A LIMITED WARRANTY. BY INSTALLING AND OR USING THIS PRODUCT, YOU WAIVE CERTAIN LEGAL RIGHTS INCLUDING THE RIGHT TO SUE OR CLAIM COMPENSATION IN THE EVENT OF PROPERTY DAMAGE, INJURY, AND OR DEATH.**

**Canature WaterGroup Canada Inc.**  
855 Park St., Unit 1  
Regina, SK, S4N 6M1  
Toll Free: (877) 288-9888









**Canature WaterGroup U.S.A. Inc.**  
6353 Commerce Drive  
Whitestown, IN, 46075  
Toll Free: (877) 288-9888

# Table of Contents

<b>SAFETY</b>	<b>3</b>
<b>FIND AND RECORD VALVE TYPE &amp; SERIAL NUMBERS</b>	<b>4</b>
<b>RECORDS &amp; CONTACTS</b>	<b>4</b>
<b>KNOW THIS BEFORE STARTING YOUR INSTALLATION</b>	<b>5</b>
<b>HOW YOUR WATER FILTER WORKS</b>	<b>7</b>
<b>FEATURES &amp; TERMINOLOGY</b>	<b>7</b>
<b>FLOW RATE INFORMATION</b>	<b>7</b>
<b>FEED WATER PARAMETERS</b>	<b>8</b>
<b>BACKWASHING INSTRUCTIONS</b>	<b>9</b>
<b>UNPACKING/INSPECTION</b>	<b>10</b>
<b>BEFORE INSTALLATION</b>	<b>11</b>
<b>PREPARATIONS</b>	<b>12</b>
<b>PLANNING YOUR INSTALLATION</b>	<b>14</b>
<b>INSTALLATION STEPS</b>	<b>16</b>
<b>UNDERSTAND THE SCREEN &amp; KEYPAD CONFIGURATION</b>	<b>18</b>
<b>START-UP INSTRUCTIONS</b>	<b>19</b>
<b>PLUMBING SYSTEM CLEAN UP</b>	<b>22</b>
<b>SYSTEM MAINTENANCE</b>	<b>23</b>
<b>SERVICING YOUR CONTROL VALVE</b>	<b>23</b>
<b>TROUBLESHOOTING GUIDE</b>	<b>25</b>
<b>COMMON SPARE PARTS</b>	<b>26</b>
<b>WARRANTY</b>	<b>28</b>

# SAFETY

Throughout this manual, certain conventions are used, including;

HAZARD SYMBOLS	
	For your own safety, please pay strict attention! Examples include: temperature, electrical, and water pressure, etc.
HAZARD SIGNALS	
	Indicates a hazardous situation that, if not avoided will result in death or serious injury, and/or property loss or damage.
	Indicates a hazardous situation that, if not avoided may result in death or serious injury, and/or property loss or damage.
	Indicates a hazardous situation that, if not avoided, could result in a minor or moderate injury, and/or property loss or damage
	Indicates important information, that if not followed may result in damage to equipment, or property loss.
WARRANTY EXCLUSIONS	
	Identify specific instructions that, if not followed, will void the warranty. The warranty provided gives you specific legal rights and otherwise limits your legal rights to the extent permitted by law. By installing and/or using this product, you are accepting these limits on your legal rights.
NOTES	
	Help you take full advantage of the system and are used to emphasize installation, operation, or maintenance information that is important but does not present a hazard.
MANDATORY SIGNS	
	Used to depict a specific behavior that <b>MUST</b> be followed to avoid the present hazard (problem).

Canature WaterGroup U.S.A. Inc. / Canature WaterGroup Canada Inc. (“Canature”) has disclosed all known risks associated with the product within this manual but cannot disclose risks that are beyond its knowledge.

Original instructions. All information, illustrations, and specifications in this manual are based on the latest information available at the time of the publication.

The right is reserved to make changes at any time without notice.

# FIND AND RECORD VALVE TYPE & SERIAL NUMBERS

There are two labels located on your Unit: **1) Control valve label** and **2) System number label**. Find and record your product model number, serial number, and valve serial number in the **Records & Contacts** section as they will be important if you need to troubleshoot.



**Control Valve Serial #** \_\_\_\_\_

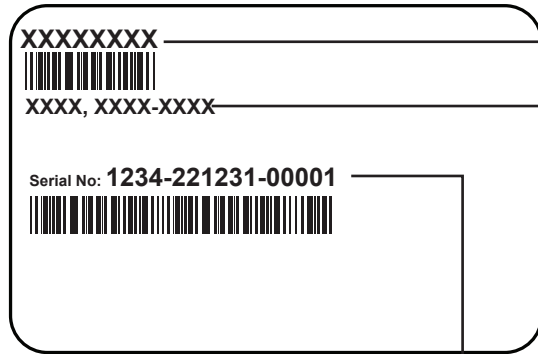

**System Serial #** \_\_\_\_\_

**Item #** \_\_\_\_\_

**Model #** \_\_\_\_\_

**NOTE**

Do NOT remove or destroy the serial number. It MUST be referenced on request for warranty repair or replacement.

## RECORDS & CONTACTS

Please have the information below filled out and available when calling in for parts or warranty:

YOUR DEALER:
Name: _____
Address: _____
Phone: _____
Other: _____
YOUR SYSTEM:
Model number: _____
Serial number: _____
Valve Serial number: _____
Date installed: _____
Installed by: _____
NOTES: _____

# KNOW THIS BEFORE STARTING YOUR INSTALLATION

- ▶ Read this manual thoroughly to become familiar with the filter and its capabilities before installing or operating.



## Failure to follow instructions could result in personal injury, property damage or death.

This manual will assist you in getting the most out of your new filter.

- ▶ The installation of this filter **MUST** be in accordance with all electrical and plumbing authorities, as well as all applicable local codes and ordinances.

Check with your local public works department for plumbing and sanitation codes.

In the event that the codes conflict with any content in this manual – the local codes should be followed.

Installation by a licensed plumber or certified water treatment professional is recommended.



- ▶ This filter is designed to operate on pressures of 30 -125 psi.

If the water pressure is higher than 125 psi, use a pressure reducing valve ahead of this filter.

- ▶ It is not uncommon for sediment, precipitated iron, or hardness to be present in water supplies. Precipitated minerals or sediment can cause damage to the seals and piston.



If precipitated minerals or sediment are present in your water supply this will be considered a harsh environment. The seals and piston would not be covered by warranty, stated or otherwise.



- ▶ Do NOT use water that is microbiologically unsafe without adequate disinfection before or after this system.

- ▶ This filter is capable of operating at temperatures between 4 °C – 43 °C or (40 °F -110 °F).



Do NOT expose filter to freezing temperatures or vacuum.

Discharge lines exposed to freezing temperatures should be positioned with a downward slope.



- ▶ Do NOT expose filter to direct sunlight.



- ▶ Do not use this filter on hot water supply lines.
- ▶ Avoid pinched O-rings during installation by applying the silicone-based lubricant supplied. Part #92360.
- ▶ It is recommended to inspect and service the control valve on an annual basis.

Cleaning and or replacement of piston, seals, and or spacers may be necessary depending on the raw water quality.

Your installer can provide a maintenance kit for this purpose.

- ▶ Rural applications should have a water analysis annually prior to system checkup or repair.



- ▶ Chlorine bleach and common iron control chemicals may generate toxic fumes when mixed.



- ▶ Always wear appropriate safety gear, such as safety glasses.

## NOTICE

The warranty provided gives you specific legal rights and otherwise limits your legal rights to the extent permitted by law. By installing and/or using this product, you are accepting these limits on your legal rights. Canature is NOT responsible for losses, injury, or death resulting from a failure to observe these safety precautions, or misuse or abuse of the equipment.

## NOTE

Check with your local public works department for applicable local plumbing and sanitation codes. Follow local codes if they differ from the standards used in this manual. Otherwise, carefully follow the instructions in this manual. Canature is not liable for any non-compliance with local requirements

# KNOW THIS BEFORE STARTING YOUR INSTALLATION (CONTINUED)

The BIF, BIFMN, BAF and BIFHS all have individual design parameters that must be followed. Please review and verify correct sizing for your application utilizing the chart supplied below and by using the following formula:

$$(\text{Iron mg/l} \quad \text{X 1}) + (\text{manganese mg/l} \quad \text{X 2}) + (\text{Hydrogen Sulphide mg/l} \quad \text{X 3}) = \text{Total Iron mg/l} \quad \text{_____}$$

## BIF, BIFMN, BAF, and BIFCC Sizing and Application Guide

<b>Chart size is as follows:</b>
100 = 1 Cu.Ft of media
150 = 1.5 Cu.Ft of media
200 = 2 Cu.Ft of media
250 = 2.5 Cu.Ft of media
300 = 3 Cu.Ft of media

# persons in the home	Model Size	Total Iron MG/L from calculation													
		1	2	3	4	5	6	7	8	9	10	15	20	25	30
1	100	Y	Y	Y	Y	Y	Y	Y	Y	Y	Y	Y	Y	Y	Y
1	150	Y	Y	Y	Y	Y	Y	Y	Y	Y	Y	Y	Y	Y	Y
1	200	Y	Y	Y	Y	Y	Y	Y	Y	Y	Y	Y	Y	Y	Y
1	250	Y	Y	Y	Y	Y	Y	Y	Y	Y	Y	Y	Y	Y	Y
1	300	Y	Y	Y	Y	Y	Y	Y	Y	Y	Y	Y	Y	Y	Y
2	100	Y	Y	Y	Y	Y	Y	Y	Y	Y	Y	N	N	N	N
2	150	Y	Y	Y	Y	Y	Y	Y	Y	Y	Y	N	N	N	N
2	200	Y	Y	Y	Y	Y	Y	Y	Y	Y	Y	Y	N	N	N
2	250	Y	Y	Y	Y	Y	Y	Y	Y	Y	Y	Y	Y	N	N
2	300	Y	Y	Y	Y	Y	Y	Y	Y	Y	Y	Y	Y	Y	N
3	100	Y	Y	Y	Y	Y	Y	Y	Y	Y	N	N	N	N	N
3	150	Y	Y	Y	Y	Y	Y	Y	Y	Y	N	N	N	N	N
3	200	Y	Y	Y	Y	Y	Y	Y	Y	Y	N	N	N	N	N
3	250	Y	Y	Y	Y	Y	Y	Y	Y	Y	Y	N	N	N	N
3	300	Y	Y	Y	Y	Y	Y	Y	Y	Y	Y	N	N	N	N
4	100	Y	Y	Y	Y	Y	Y	Y	N	N	N	N	N	N	N
4	150	Y	Y	Y	Y	Y	Y	Y	Y	N	N	N	N	N	N
4	200	Y	Y	Y	Y	Y	Y	Y	Y	Y	N	N	N	N	N
4	250	Y	Y	Y	Y	Y	Y	Y	Y	Y	N	N	N	N	N
4	300	Y	Y	Y	Y	Y	Y	Y	Y	Y	N	N	N	N	N
5	100	Y	Y	Y	Y	Y	Y	N	N	N	N	N	N	N	N
5	150	Y	Y	Y	Y	Y	Y	N	N	N	N	N	N	N	N
5	200	Y	Y	Y	Y	Y	Y	Y	Y	N	N	N	N	N	N
5	250	Y	Y	Y	Y	Y	Y	Y	Y	Y	N	N	N	N	N
5	300	Y	Y	Y	Y	Y	Y	Y	Y	Y	N	N	N	N	N
6	100	Y	Y	Y	Y	Y	N	N	N	N	N	N	N	N	N
6	150	Y	Y	Y	Y	Y	N	N	N	N	N	N	N	N	N
6	200	Y	Y	Y	Y	Y	Y	Y	N	N	N	N	N	N	N
6	250	Y	Y	Y	Y	Y	Y	Y	Y	N	N	N	N	N	N
6	300	Y	Y	Y	Y	Y	Y	Y	Y	Y	N	N	N	N	N



# HOW YOUR WATER FILTER WORKS

The BIF/BAF systems work by adding oxygen to the incoming water by passing it through a bubble of compressed air. The water is then passed through a special filter bed.

The special media not only increases the pH of the water to enhance iron removal but also acts as a physical barrier to trap iron precipitate.

As more water passes through this iron filter, the oxygen in the unit is used up, and the media gets loaded with iron. The regeneration process then begins in order to replenish the supply of oxygen, and to backwash the precipitated iron trapped in the media bed.

The iron removal efficiency will be more effective with high pH water.

## FEATURES & TERMINOLOGY

### Scrolling Diagnostics

By pressing any button to light the LCD display, the unit will automatically begin scrolling important information for diagnostic purposes.

### Remaining Gallons

The amount of treated water capacity until the next regeneration is required.

### Total Gallons

The total amount of water the system can filter between regenerations.

### Regen Time

Time of day that the filter is scheduled to regenerate.

### Estimated Days to Next

Estimation of days to the next regeneration based on current consumption and capacity.

### Last Regeneration

The date of the last regeneration cycle.

## FLOW RATE INFORMATION

At the stated service flow rates, the pressure drop through these devices will not exceed 15 psig.

Peak flow rates are intended for intermittent use only (10 minutes or less) and are for residential applications only. Do not use peak flow rate for commercial applications or for a continuous rate when treated water supplies are geothermal heat pump, swimming pool, etc.

For satisfactory operation, the pumping rate of the well system must equal or exceed indicated backwash flow rate.

# FEED WATER PARAMETERS

## ALL UNITS

**Maximum TDS** = 2000 ppm  
**Maximum Sulphates** = 500 ppm  
**Maximum Hardness** = 75 gpg  
**Maximum Tannin** = 0.0 ppm

## BIF

**Maximum Iron** = 30 ppm ferrous or ferric  
**Maximum Manganese** = 0.0 ppm  
**Maximum Hydrogen Sulfide** = 1.0 ppm  
**pH** = 7.0. to 8.5

## BIFMN

**Maximum Iron** = 30 ppm ferrous or ferric  
**Maximum Manganese** = 1.0 ppm  
**Maximum Hydrogen Sulfide** = 5.0 ppm  
**pH** = 6.5 to 7.5

## BAF

**Maximum Iron** = 30 ppm ferrous or ferric  
**Maximum Manganese** = 0.0 ppm  
**Maximum Hydrogen Sulfide** = 0.0 ppm  
**pH** = 7.0. to 8.5

## BIFCC (Catalytic Carbon)

**Maximum Iron** = 0.0 ppm ferrous or ferric  
**Maximum Manganese** = 0.0 ppm  
**Maximum Hydrogen Sulfide** = 5.0 ppm  
**pH** = 7.0. to 8.5

## Optional Media Beds:

- Chemfree (BIF Models) - Removes iron and manganese from water. Recommended for low pH water.
- Multimedia- Traps precipitated iron from the water. Recommended for high pH water.
- Carbon (BIFCC Models) -for reduction for Hydrogen Sulfide.
- Birm (BAF Models) - Removes iron and manganese from water. Recommended for high pH water.

## Standard Chemfree Filter (BIF and BIFMN Models)

This special media not only increases the pH of the water to enhance iron, manganese and hydrogen sulfide removal but also acts as a physical barrier to trap iron precipitate.

The filter will automatically adjust the pH to neutral or higher on acid water without an acid neutralizer. The ability to raise pH greatly enhances the filter's ability to remove iron efficiently.

Replenishment of this media that raises pH will be required periodically, depending on how low the raw water pH is the amount of manganese (Mn) present in the water and usage rate. Models ending in 'M' are required when raw water has up to 1.0 mg/l of manganese or when pH is below 7.0. Over a period of time, it may become necessary to add more media to the unit. Adding media is necessary only when water has low pH or manganese is present.

## Multimedia Chemical Free Iron Filter - (BIFMM Models)

This media acts as a catalyst for the removal of iron and manganese from the water but require pre-oxidation. The water is pre-oxidized from the air bubble on the top of the tank and this media removes the iron and manganese from the water. This is not recommended to remove hydrogen sulfide from the water and requires high pH water.

The media is not sacrificial hence no replenishment is required.

## Carbon Filter (BIFCC Models)

Hydrogen sulfide (H<sub>2</sub>S) is a nuisance to homeowners and water treatment professionals alike. These add objectionable sulfur-like taste and "rotten egg" odor to drinking water. Left untreated, it can lead to corrosion in drainage pipes and concrete sewers.

Groundwater systems are the most common drinking water source for sulfide contamination because of the anaerobic environment in which groundwater exists. Chlorination has been considered the most practical method for POE systems, but is often difficult to implement because continuous chemical addition and ongoing maintenance is required. The formation of THMs is also a concern.

Sulfide problems in surface water sources are much less frequent because of the natural aeration that occurs in most flowing surface water sources. Aeration is the most common treatment method in terms of volume of water treated annually because it's inexpensive, easy to maintain and doesn't produce potentially harmful reaction products such as tri-halo-methanes (THMs).

Another method is the use of catalytic carbon to sulfide reduction through oxidation of sulfides with dissolved oxygen present in the water. Reduction of sulfides with catalytic activated carbon first involves adsorption of the sulfide species and then catalytic oxidation. The dissolved oxygen (minimum required 4 ppm) reacts with sulfides and oxidizing them to elementary sulfur and sulfates.

Our Hydrogen Sulfide reduction filter combines aeration with catalytic carbon technology to effectively reduce sulfur from water. Following is the information on our Filter System for the reduction of sulfides from water.

## Birm Filter (BAF Models)

The air in the tank will precipitate the iron from water and this filter media will trap the iron particles. Recommended for neutral to high pH water.



# BACKWASHING INSTRUCTIONS

The BIF, BIFMN, BAF and BIFHS all have individual design parameters that must be followed.

## Instructions for Chart Use

From your water test results add the following together: **Iron ppm plus manganese mg/l x 2 plus Hydrogen sulfide ppm x 3**. EG **1ppm plus .5 x 2 = 1.0 plus .5 x 3 = 1.5** will give you a compensated iron amount of **3.5** locate **3.5** (round up) on the chart if assuming it fits into the area that is shaded with a **Y** in it then the unit is sized correctly. Factory setting is **600 gallons** or **4 days** between regenerations. Please adjust gallons accordingly, do not adjust the day setting as the unit is required to regenerate at least every **4 days** to replenish the air pocket in the air tank. Should the compensated iron fall into the area shown with an **N** please contact your sales representative for additional information before installation.

$$(\text{Iron mg/l } \underline{\hspace{2cm}} \times 1) + (\text{manganese mg/l } \underline{\hspace{2cm}} \times 2) + (\text{Hydrogen Sulphide mg/l } \underline{\hspace{2cm}} \times 3) = \text{Total Iron mg/l } \underline{\hspace{2cm}}$$

		ppm compensated iron	1	2	3	4	5	6	7	8	9	10	15	20	25	30
People in home	Total Gallons available	3200	1600	1050	800	650	500	450	400	350	300	200	150	100	100	
1		Y	Y	Y	Y	Y	Y	Y	Y	Y	Y	Y	Y	Y	Y	Y
2		Y	Y	Y	Y	Y	Y	Y	Y	Y	Y	Y	N	N	N	N
3		Y	Y	Y	Y	Y	Y	Y	Y	Y	Y	N	N	N	N	N
4		Y	Y	Y	Y	Y	Y	Y	N	N	N	N	N	N	N	N
5		Y	Y	Y	Y	Y	Y	N	N	N	N	N	N	N	N	N
6		Y	Y	Y	Y	Y	N	N	N	N	N	N	N	N	N	N

Note importance of pH in application and setting of your equipment

While the BIF and BIFMN product does have the ability to stabilize and in fact raise the PH some this is not always enough to complete the oxidation process.

If your raw pH is between 7.0 and 7.3 the effective oxidation time is cut in half so please set the unit accordingly (half the amount of gallons noted on the chart)

If the Raw pH is between 6.8 to 7.0 the effective oxidation time is cut by .75 so please set the unit accordingly ( 1 quarter the amount of gallons noted on the chart)

if the Raw pH is lower than 6.8 additional pH correction measures will need to be taken please contact your representative.

# UNPACKING/INSPECTION

Be sure to check the entire unit for any shipping damage or parts loss. Also note damage to the shipping cartons. Contact the transportation company for all damage and loss claims. The manufacturer is not responsible for damages in transit.

Small parts, needed to install the filter, are in a parts box. To avoid loss of the small parts, keep them in the parts bag until you are ready to use them.

## What is included in the box?

1. Control Valve
2. Tank 1 c/w Parallel Adaptor
3. Parts Box
4. Owners Manual
5. Flex Connectors
6. Tank 2 c/w Adaptor

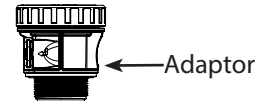
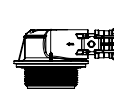
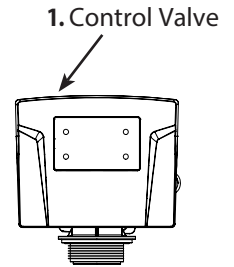
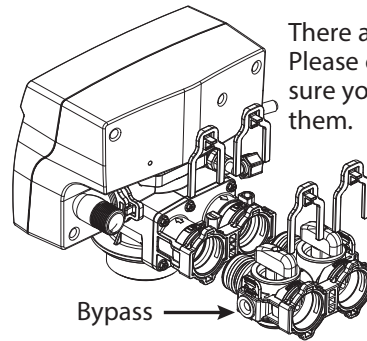
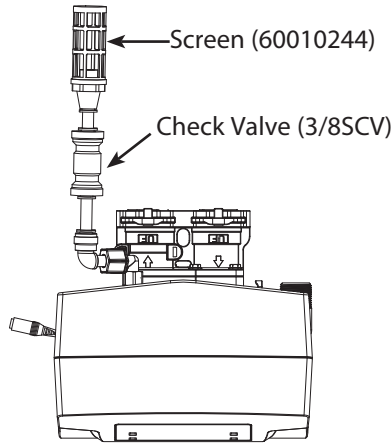

**3. Parts Box**

- 92360 Grease Packet
- 60010252 2 x 1" Elbow Adapter
- 60010006 Bypass Tool
- 60010590 O-rings Attached
- 60010004 Bypass with 4 Red Clips
- 60010052 Transformer
- 92387 2 x Clips

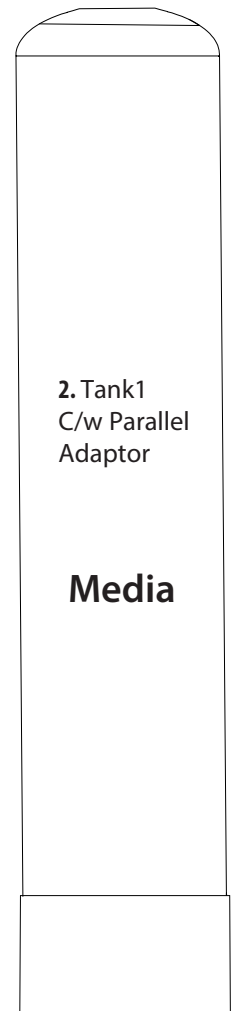
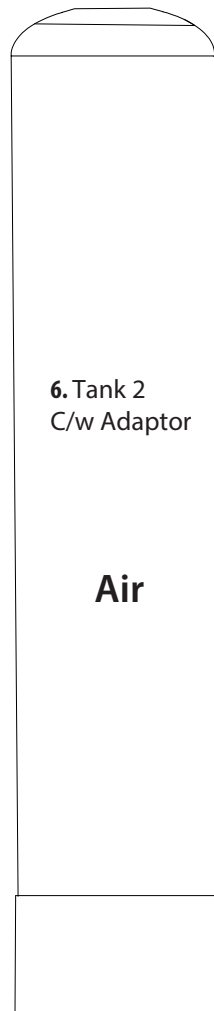

**5. Parts**

- Connector Pipes. 8" - 12" or 13" - 18" Tanks
- Red Clips (4pcs)
- O Ring / 1" BSP Straight (4pcs)

# BEFORE INSTALLATION

Make sure you have a copy of your most recent water test results. If your water has not been tested previously, your professional installer can obtain a water sample bottle to be sent to one of our facilities for a free analysis. **It is important that this product not be installed until you have this information.**

In all cases where metal pipe was originally used and is later interrupted by poly pipe, or the Noryl bypass valve, an approved ground clamp with physical separation and no less than #6 copper conductor must be used for continuity, to maintain proper metallic pipe bonding.

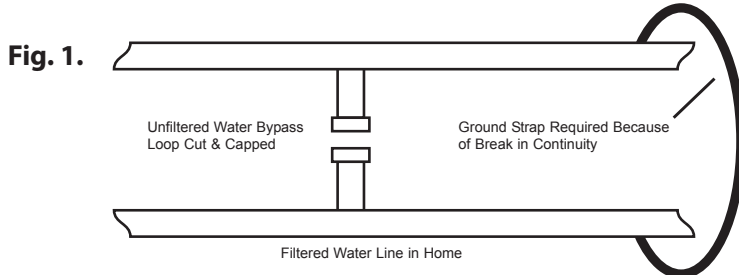

## WARNING

If the ground from the electrical panel or breaker box to the water meter or underground copper pipe is tied to the copper water lines and these lines are cut during installation of the bypass valve and/or poly pipe, an approved grounding strap must be used between the two lines that have been cut in order to maintain continuity. The length of the grounding strap will depend upon the number of units being installed and/or the amount of copper pipe being replaced with plastic pipe.

**See Figure 1.**

## MECHANICAL

Do NOT use petroleum-based lubricants such as petroleum jelly, oils or hydrocarbon based lubricants. Use only 100% silicone lubricants (packet Part #92360 provided in parts kit). All plastic connections should be hand tightened only. Thread tape may be used on connections that do not use an O-ring seal.

Do NOT use pliers or pipe wrenches except when indicated by nut shape, e.g., pipe adapters. All plumbing must be completed according to local codes. Soldering connections should be done before connecting any plastic pieces to the pipe as excessive heat can damage them.

## TOOLS REQUIRED FOR INSTALLATION

- ▶ Two adjustable wrenches.
- ▶ Additional tools may be required if modification to home plumbing is required.
- ▶ Plastic inlet and outlet fittings are included with the filter. To maintain full valve flow, use of  $\frac{3}{4}$ " or 1" [1.9 cm or 2.54 cm] pipes to and from the filter. You should maintain the same or larger pipe size as the water supply pipe to the filter inlet and outlet.
- ▶ Use copper, brass, or PEX pipes and fittings.
- ▶ Some codes may also allow PVC plastic pipe.
- ▶  $\frac{5}{8}$ " [15.8 mm] Outside Diameter drain line is needed for the valve drain.
- ▶ Drain line tubing may be needed for the optional brine tank overflow fitting.

## NOTE

Use of a competent installer or plumbing professional to ensure this product is installed in accordance with local plumbing codes is recommended. Canature is not liable for any non-compliance with local requirements.

# PREPARATIONS

## MEDIA INSTALLATION

Follow the steps below for proper media loading.

1. Temporarily plug the open end at the top of the riser (distribution) tube with tape.

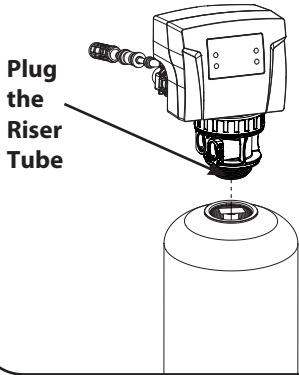

2. Ensure the bottom of the riser tube remains seated in the depression at the bottom of the tank. Fill tank one-quarter full with water to protect the distribution tube during gravel installation.

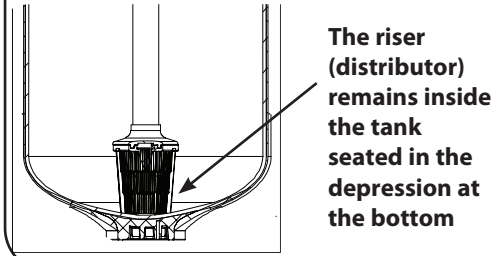

3. Fill the gravel support bed first. A large funnel makes filling the tank much easier. Order part #99003 separately for your own funnel. Slowly add the gravel. Depending on the type of system, add the resin, or media next.

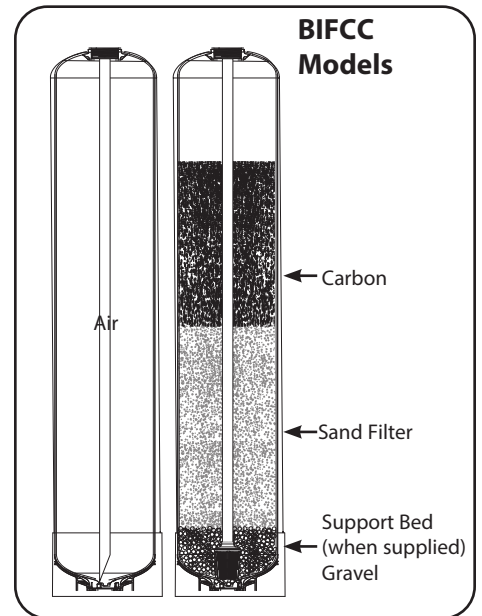
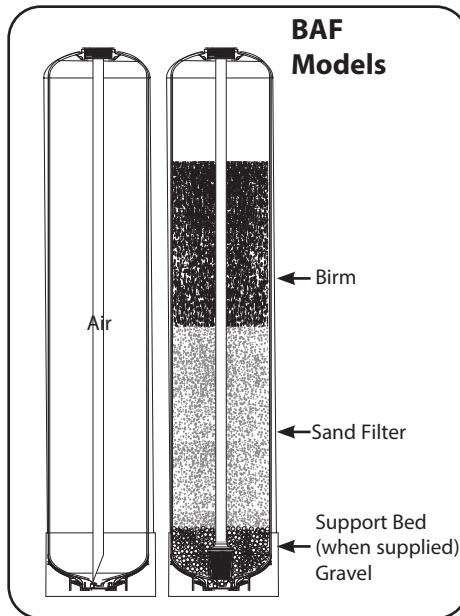
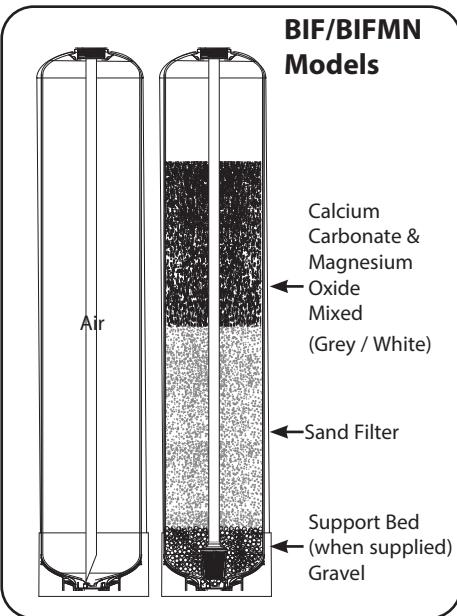
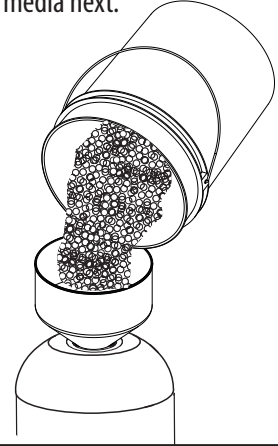

Fill tank one quarter full of water to protect distribution during gravel installation.

Place the media into the tank in the order indicated above. Slowly and carefully add the gravel support bed and the filtration media leveling each layer as it is placed into the tank.

Fill support bed (if supplied) first. During the filling process, ensure the distributor tube stays on the bottom of the tank, reasonably centered. Remove the tape from the distributor once media is loaded. Whenever possible, fill the tank outdoors to avoid problems with dust. If filling indoors, a dust mask should be worn.

### NOTE

If severe loss in water pressure is observed when the filter unit is initially placed in service, the filter tank may have been laid on its side during transit. If this occurs, backwash the filter to 'reclassify' the media.



 Wear a Dust Mask. Airborne particles could pose potential health risks.

# PREPARATIONS

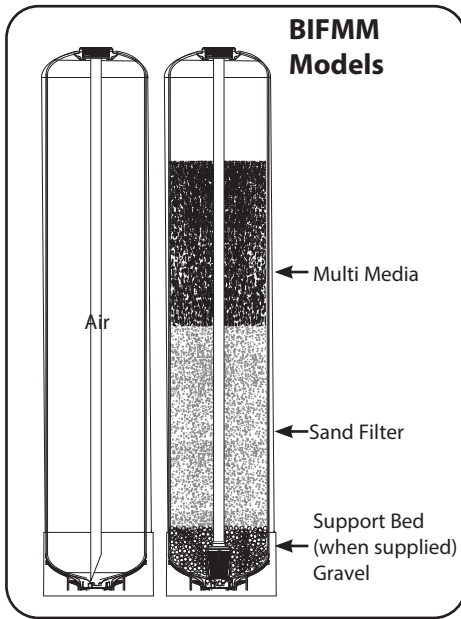

4. Apply the supplied lubricant (part #92360) to the internal O-ring at the bottom of the control valve. Apply lubricant to the larger O-ring on the bottom of the valve that seals with the tank threads.

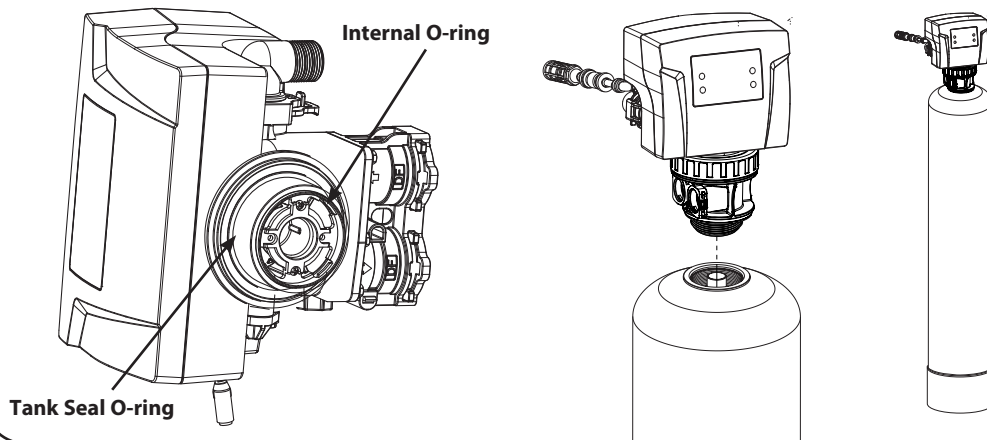

## NOTICE

Do NOT use petroleum-based lubricants as they will cause swelling of the O-ring seals.

5. Remove the tape from the top of the riser tube. Carefully position the valve over the riser tube, inserting riser into the internal O-ring. Turn the valve clockwise into the threads of the tank until secure.

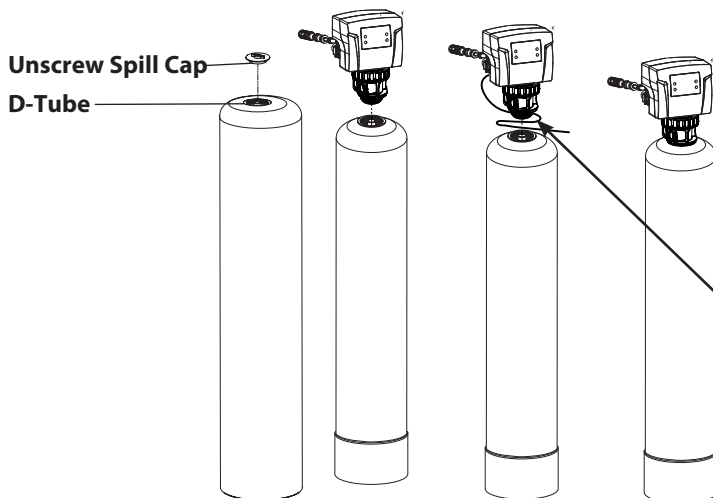



## NOTICE

Make sure the quick connect power cord is not yet connected to prevent the cord getting caught between the threads of the tank and the valve.

# PLANNING YOUR INSTALLATION

## WATER FILTER INSTALLATION LAYOUT

Select the location for your filter tank with care. Various conditions that contribute to proper location include:

1. All installation procedures must conform to local or regional plumbing codes. Canature is not liable for any non-compliance with local requirements
2. Outside taps used to water lawns and gardens should be isolated from the water line required to supply untreated water to the inlet of the water filter – a separate (new) line may be needed.
3. Where required by local plumbing codes, a check valve may need to be installed. Canature is not liable for any non-compliance with local requirements
4. Locate filter as close as possible to the water supply source.
5. Locate filter as close as possible to a floor or laundry tub drain and a 120 volt AC electrical outlet.
6. Filters should be located before the water heater on the supply line. If closer than three (3) metres [10 feet], install a check valve in accordance with local plumbing codes.
-   7. Do NOT install a filter in a location where freezing temperatures occur. Freezing may cause permanent damage to this type of equipment and will void the factory warranty. Freezing could also result in flooding and / or property loss and damage.
8. Allow sufficient space around the unit for easy servicing.
-  9. Keep the filter out of direct sunlight.

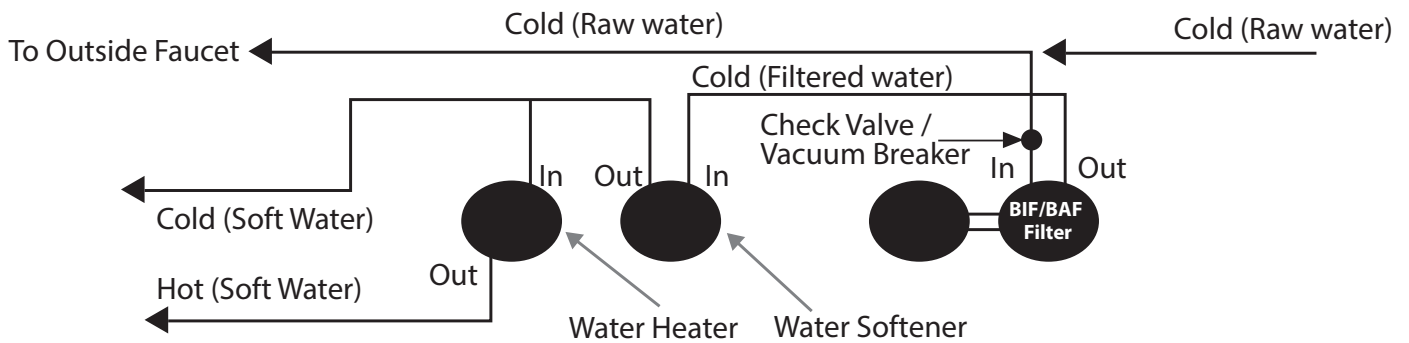

### \*NOTE

Check local plumbing codes requirements for use of check valve(s), back-flow prevention, or vacuum breakers. Canature is not liable for any non-compliance with local requirements.

# PLANNING YOUR INSTALLATION (CONTINUED)

## WATER FILTER INSTALLATION

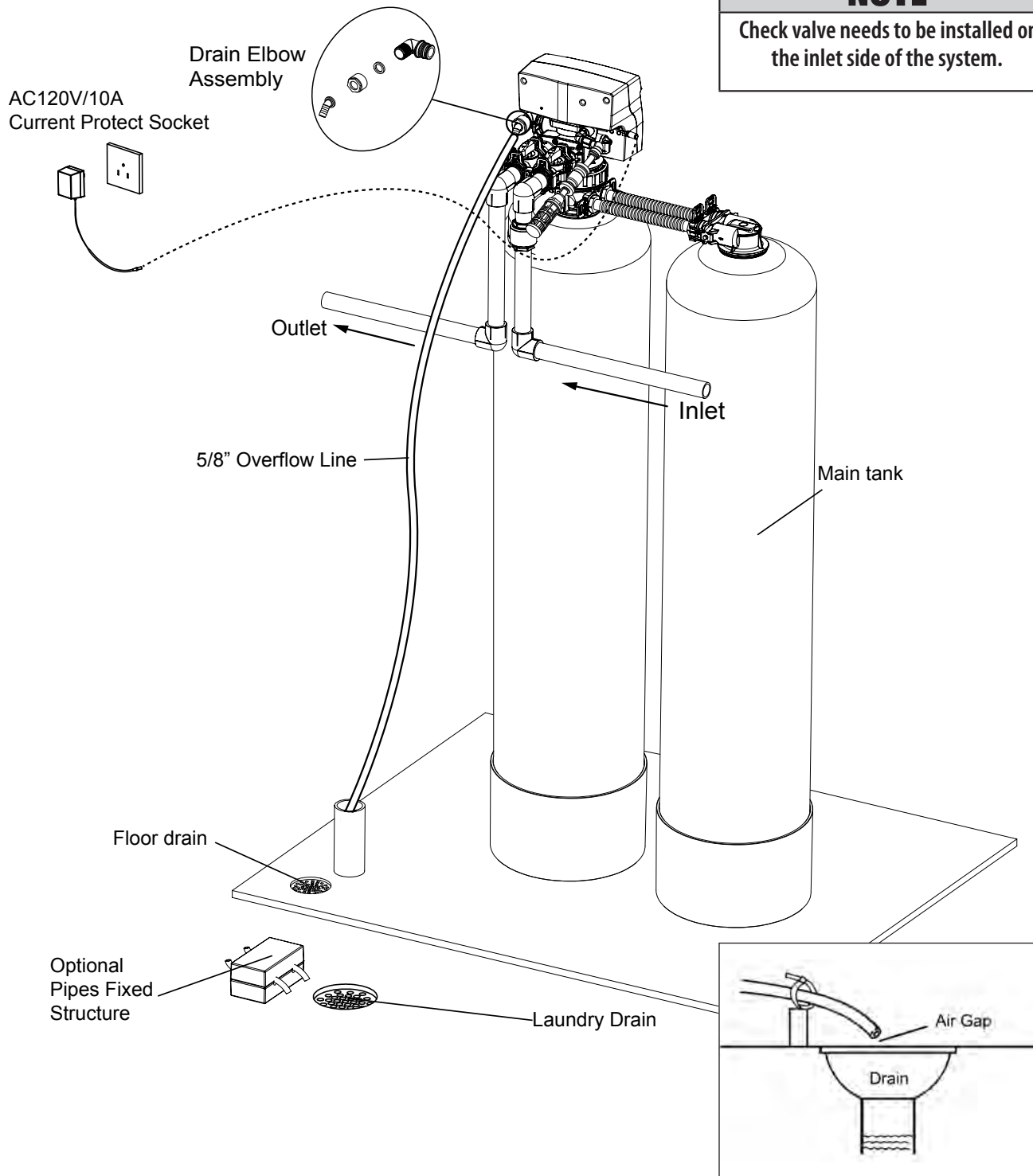

**NOTE**  
Check valve needs to be installed on the inlet side of the system.

 **CAUTION**  
Never insert drain line directly into a drain, sewer line, or trap. Always allow an air-gap between the drain line and the wastewater to prevent the possibility of sewage being back-siphoned into the filter.

**NOTE**  
Waste connections or drain outlet shall be designed and constructed to provide for connection to the sanitary waste system through an air-gap of 2 pipe diameters or 1 inch (22 mm) whichever is larger.

# INSTALLATION STEPS

## TO BEGIN YOUR INSTALLATION:

1. Make sure the bypass is attached securely to the control valve.
2. Apply thread tape to threaded connections elbow plumbing adaptors
3. Apply the supplied lubricant (#92360) to the O-rings of the fittings.
4. Connect the supplied elbow plumbing adaptors to the bypass with red clips.
5. Connect the inlet and outlet of the water filter to the plumbing of the house.

### NOTICE

Any solder joints near the valve must be done before connecting any piping to the valve. Failure to do this could cause damage to the valve.

### NOTICE

Do NOT use pipe thread compound as it may attack the material in the valve body.

### NOTICE

Failure to leave enough distance could cause damage to the valve. Always leave at least 6" [152 mm] between the valve and joints when soldering pipes that are connected to the valve.

6. For the drain line connection; attach a 1/2" [12.7 mm] Inside Diameter (ID), 5/8" [15.875 mm] Outside Diameter (OD) drain hose to the drain line fitting.
  - a. Run the drain line to a floor or laundry drain.
  - b. Complete any necessary plumbing to maintain a proper air gap.

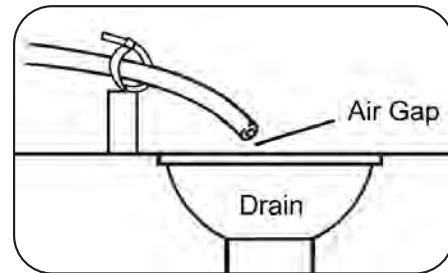

### NOTE

The waste connections or drain outlet shall be designed and constructed to provide for connection to the sanitary waste system through an air-gap of 2 pipe diameters or 1" [25.4 mm] whichever is larger.



### CAUTION

Never insert drain line directly into a drain, sewer line, or trap. Always allow an air-gap between the drain line and the wastewater to prevent the possibility of sewage being back-siphoned into the filter.

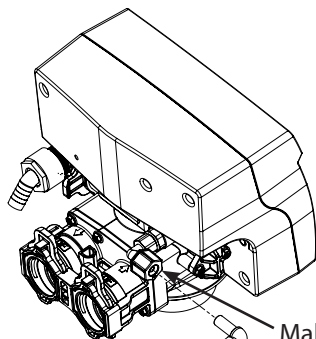

Make sure both brass and plastic nuts are tightened well

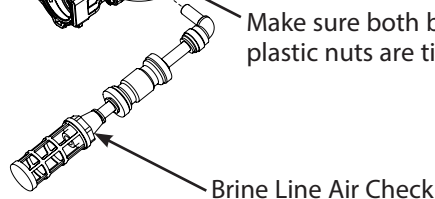

Brine Line Air Check



# INSTALLATION STEPS (CONTINUED)

7. Using the included Allen key, place the unit in the bypass position.
  - a. Slowly turn the main water supply ON.
  - b. At the nearest cold treated water tap, remove the tap screen, OPEN the tap and let water run a few minutes or until the system is free of any air or foreign material resulting from the plumbing work.

## MANUAL WATER BYPASS

In case of an emergency, or to perform conditioner maintenance, you can isolate your water conditioner from the water supply using the bypass valve located at the back of the control.

In normal operation the bypass is OPEN with the ON/OFF knobs in line with the INLET and OUTLET pipes, i.e., the black marks in the vertical position. See SERVICE below.

To isolate the conditioner, simply rotate the knobs as indicated to the CLOSE position until they lock. You can continue to use your water related fixtures as the water supply is bypassing the conditioner. However, the water you use will be untreated.

To resume treated service, OPEN the bypass valve by rotating the knobs back to the SERVICE position.

<b>NOTE</b>
If the tap has a screen, it should be removed to allow debris to flush out of the plumbing.

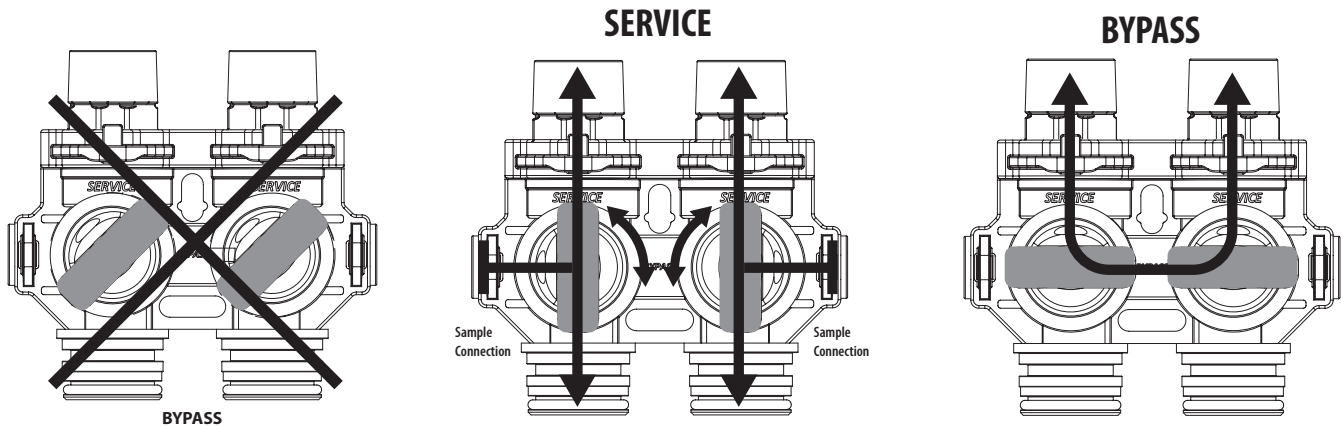

<b>NOTE</b>
Please make sure bypass knobs are completely open otherwise the untreated water may enter through the valve.

9. Make sure there are no leaks in the plumbing system before proceeding. Shut the water tap OFF when the water runs clean.

# UNDERSTAND THE SCREEN & KEYPAD CONFIGURATION

The control valve is controlled with simple, user-friendly electronics, displayed on an LCD screen.

## Connect the Transformer



Connect the transformer to the unit by plugging the 12 volt transformer into a 120 VAC 60 Hz outlet.

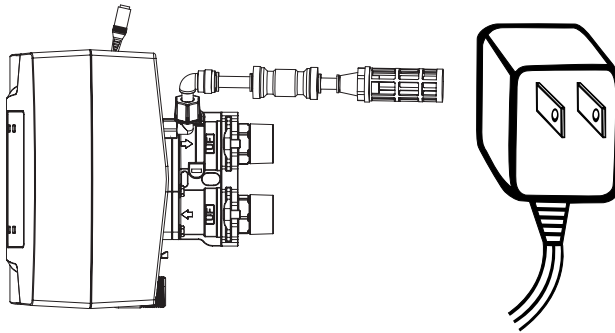

When the power is connected, the screen will show the following information:

**Key Pad Configuration** – the terminology used on the control valve label may vary by model. For the purpose of programming, this manual will use numbers associated with each button position as shown below:

- 1** This function is to enter the basic set up information required at the time of installation.
- 3** This function is to initiate an immediate or delayed manual regeneration.
- 2/4** Increase or decrease the value of the settings while in the programming mode.

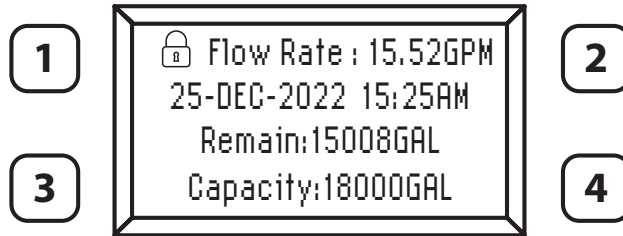

# START-UP INSTRUCTIONS

Now that your water conditioner is plumbed into position it is time to start up and program the unit.

## STEP 1. PURGE AIR FROM THE UNIT



1. Press and hold **button one (1)**, the display will read **"PRESS [ ] 5 Seconds to Unlock"**. After 5 seconds, the display will beep confirming unlock.

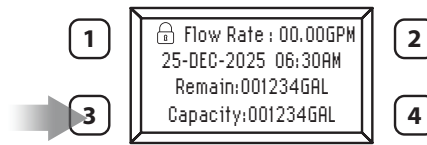

2. Press and hold **button three (3)** to start Manual Regeneration process.
3. Press and hold any button to advance to Backwash.

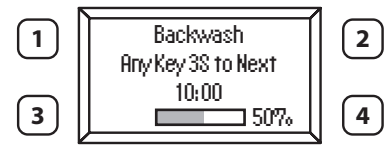

4. The display will indicate the time remaining. **ALLOW TO FINISH FULL CYCLE.**

5. **Open the bypass inlet very slowly** until there is a steady stream of water at the drain. Opening the bypass inlet too quickly could result in resin being expelled from the unit and into the plumbing lines. With the valve in the backwash position the unit will purge air from the system, sending it to the drain. This may take longer than the programmed backwash cycle time, so unplug the power so that the valve will remain in the backwash position.
6. With the bypass inlet now fully open, let the system run until all the air is purged and there is a steady stream of water at the drain.
7. Reconnect the power, press and hold any button to advance to the refill position and allow the unit to refill to 1" [25.4 mm] above the grid board or 3" [76.2 mm] of water in cabinet models – this may require manually advancing the unit through its cycles more than once. Alternatively, you can press and hold any button to advance to the service position and manually add the required amount of water as described in step 1.
8. Allow the unit to return to the SERVICE position.
9. Slowly open the bypass OUTLET knob until fully open.

### NOTE

If severe loss in water pressure is observed when the conditioner unit is initially placed in service, the conditioner tank may have been laid on its side during transit. If this occurs, backwash the conditioner to 'reclassify' the media.



### MANDATORY

Be sure to open the bypass inlet very slowly. Do NOT FULLY open the bypass inlet until there is a steady stream of water at the drain as this will result in media being expelled from the unit

# START-UP INSTRUCTIONS (CONTINUED)

## STEP 3. HOW TO SET DATE AND TIME, MANUAL REGENERATION, DEALER INFO

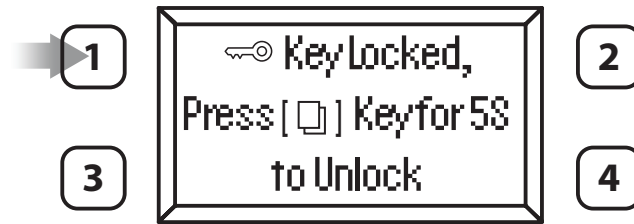

1. Press and hold **button one (1)**, the display will read "PRESS [ ] 5 Seconds to Unlock".
2. After 5 seconds, the display will beep confirming unlock.
3. Press **button one (1)** [ ] to enter user programming.

## Date & Time

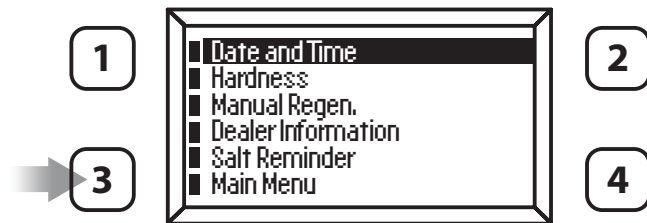

1. Press **button three (3)** to select Date and Time.

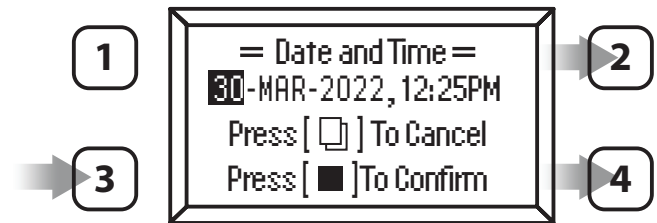

2. Press **buttons two (2)** or **four (4)** to adjust Date and Time. Press **button three (3)** to Confirm.

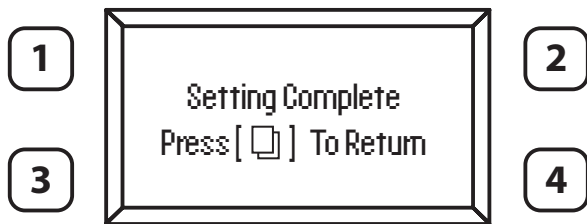

3. Setting complete.

### DATE AND TIME

Time of day is for normal operation of system and the scheduling of the regeneration time. The date is used in a diagnostic function to track the last time the system regenerated.

# OTHER MAIN MENU FEATURES

## To Initiate a Manual Regeneration

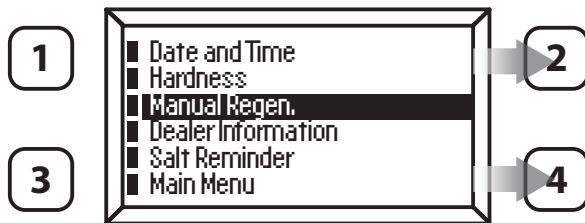

1. Press **buttons two (2) or four (4)** to select Manual Regen.  
Press **button three (3)** to Confirm.

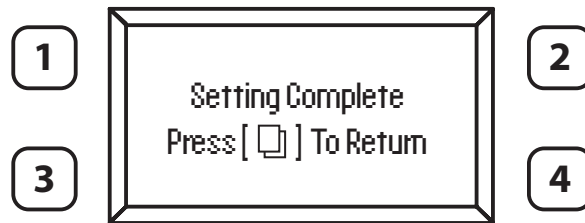

3. Setting complete.

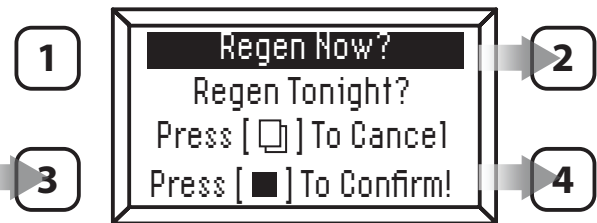

2. Press **buttons two (2) or four (4)** to select Regen Now or Regen Tonight.  
Press **button three (3)** to Confirm.

## Dealer Info

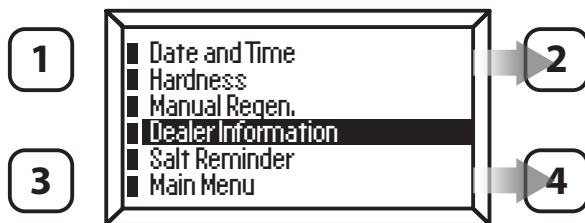

1. Press **buttons two (2) or four (4)** to select Dealer Information.  
Press **button three (3)** to Confirm.

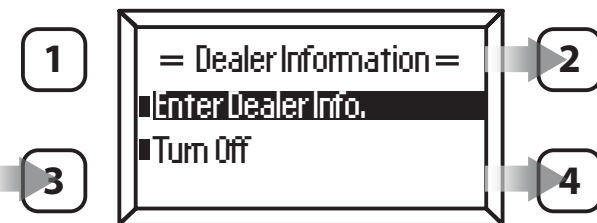

2. Press **buttons two (2) or four (4)** to select.  
Press **button three (3)** to Confirm.



3. Press **buttons two (2) or four (4)** to select desired Letters or Numbers.  
Press **button three (3)** to Confirm.

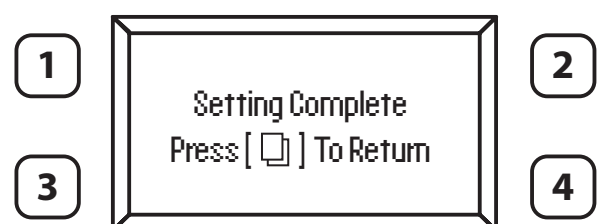

4. Setting complete.

# PLUMBING SYSTEM CLEAN UP

The following procedures are guidelines only but have proven successful in most instances. Under no circumstances should any procedure outlined below be followed if contrary to any other household appliances manufacturer's instruction(s). Should there be any questions concerning the advisability of performing a procedure, it is strongly recommended that the dealer be consulted prior to performing the procedure. Canature is not liable for any damages that result of failing to follow the household appliance manufacturer's instructions and/or any issues that arise from following those instructions.

## WATER HEATER

If the water heater has been exposed to both iron and hardness for a long period of time, replacement of the heater tank maybe the only practical solution to prevent continued staining originating from this source. After completing the installation of the filter, clean the water heater by following these instructions;

1. Turn the energy supply to the water heater OFF and shut the heater inlet water valve OFF.
2. Drain hot water tank completely. OPEN the Inlet Water Valve allowing the heater tank to be refilled with iron free water. Continue flushing until clear water runs to the drain.
3. If, after 30 minutes flushing, the water does NOT clear, terminate flushing operation.
4. REFILL hot water heater with water and pour approximately .5 gal or [ .19 Litres] of household bleach into the top of the heater tank. Allow bleach solution to stand in tank for thirty (30) minutes. Flush tank.
5. Turn the energy supply back ON.

## DISHWASHER

Dishwashers may have scale buildup due to prolonged exposure to hard water effecting the factory rated performance. Consult the owner's handbook and follow the manufacturer's instructions.

## TOILET FLUSH TANKS

### To clean up toilet flush tanks:

1. Pour 4 to 6 fluid ounces [120-175 millilitres] of resin mineral cleaner, Pro-Rust Out or any other suitable cleaner that contains a mild acid, such as CLR, into flush tanks and bowls, and let stand for one (1) hour.
2. When installation is completed, flush toilets several times with conditioned water.
3. If stains or deposits return, check that the lines are connected to treated water.

# SYSTEM MAINTENANCE



Maintenance of your new water filter requires very little time or effort but is essential. Regular maintenance will ensure many years of efficient and trouble-free operation. Check with your local dealer about setting up a regular maintenance plan. Failure to follow maintenance instructions and schedule will result in the unit failing to operate properly and void your warranty.

## CARE OF YOUR FILTER

To retain the attractive appearance of your new water filter, occasionally clean it with a mild soap solution. Do NOT use abrasive cleaners, ammonia, or solvents.

## SERVICE SCHEDULE

- The seals and spacers along with the piston assembly should be inspected/cleaned or replaced annually or as required depending on the inlet water quality and water usage. See Inspection and Replacement of Piston Assembly and Seal and Spacer Kit.
- The injectors should be cleaned/inspected or replaced annually or as required depending on the water quality and use. See Clean Injector Assembly.
- Your inlet water quality and water consumption will determine how often the media should be replenished or replaced. Check with your water treatment expert for the media bed change frequency.
- Maintenance materials – Please see Common Spare Parts.
- Type M units only. The pH of your Raw water and treated water should be monitored at least monthly for the first year to determine when additional media will be required. Once the pH is equal or below 7.0 additional media will be needed to refresh the media bed please order item 95442 5 lb Jar of pH Adder.
- Check and clean the cross pipes and air tank annually.

## SERVICING YOUR CONTROL VALVE

### BEFORE SERVICING, YOU WILL NEED TO:

1. Shut the water supply to the filter OFF, put the filter into the BYPASS position.
2. Relieve water pressure in the filter by stepping the control into the backwash momentarily.
3. Return the control to the SERVICE position.
4. Unplug the electrical cord.
5. Disconnect the drain line connection.

Always follow these steps prior to servicing the valve.

## POWERHEAD REMOVAL

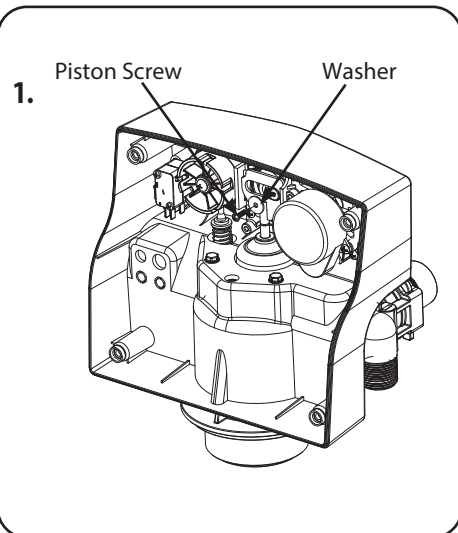

### To remove the powerhead:

1. Remove screw & washer from piston rod link.

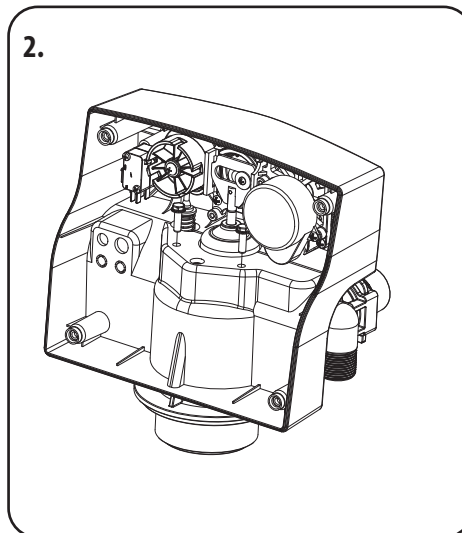

2. Remove two (2) bolts securing powerhead to body.

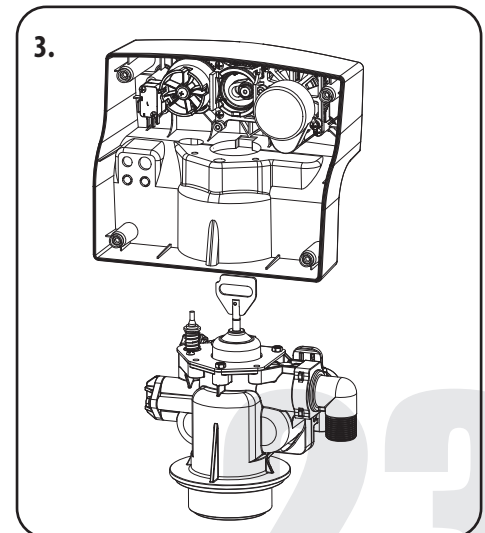

3. Remove powerhead from body.

	<b>CAUTION</b>
<b>RISK OF FLOOD</b> Disassembly while under pressure can result in flooding.	

	<b>WARNING</b>
<b>RISK OF SHOCK</b> Unplug the unit before removing the cover or accessing any internal control parts.	

# SERVICING YOUR CONTROL VALVE (CONTINUED)

## INSPECTION & REPLACEMENT OF PISTON ASSEMBLY AND SEAL & SPACER KIT

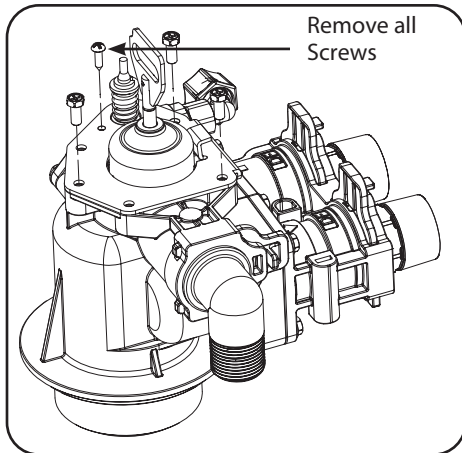

1. Follow steps 1 to 3 of Powerhead Removal above.
2. Remove four (4) screws from the plate on the valve body.

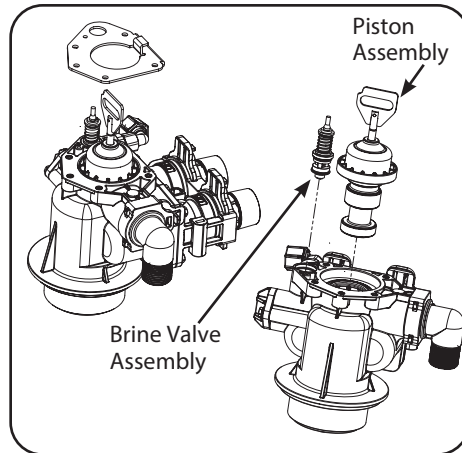

3. Remove the plate from the valve body and pull the piston assembly from the valve. The brine valve assembly can also be removed in this stage.
4. If only lubricating, remove the piston assembly, grease it with silicone lubricant (Part #92360) and put back in.

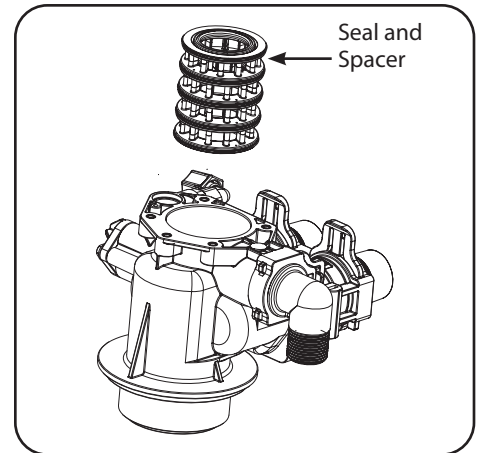

5. Replace seal and spacer set as shown. Place spacer in then a seal and repeat until finishing with a seal.
6. Lubricate the piston assembly with silicone lubricant (Part #92360) and then replace the Piston Assembly.

### NOTICE

Do NOT use petroleum-based grease products during replacement and assembly.

## INSPECTION & REPLACEMENT OF INJECTORS

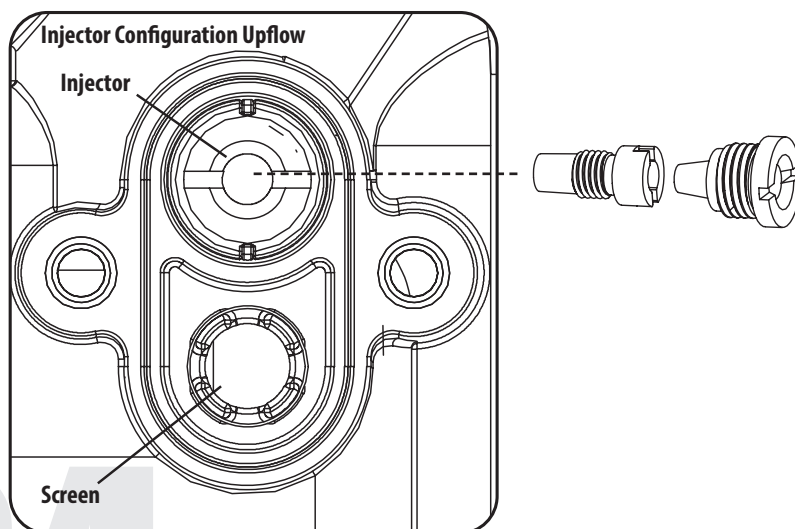



# TROUBLESHOOTING GUIDE

## NOTE

Before attempting any troubleshooting, be sure to test the water. The tests should include;

1. Raw water
2. Hot treated water
3. Cold treated water.

Problem	Cause	Correction
<b>1. Filter bleeds taste and odor or sediment</b>	<ul style="list-style-type: none"> <li>A. Bypass valve is open</li> <li>B. Electrical service to unit has been interrupted</li> <li>C. Defective or stripped media bed</li> <li>D. Quality of water has worsened</li> <li>E. Filter capacity too small</li> <li>F. Filter not backwashing enough</li> <li>G. Excessive water usage - calendar clock models</li> </ul>	<ul style="list-style-type: none"> <li>A. Close bypass valve</li> <li>B. Assure permanent electrical service (check fuse, plug or switch)</li> <li>C. Replace media</li> <li>D. Have water sample analyzed to determine any change</li> <li>E. Replace with larger unit or add another filter</li> <li>F. Be sure flow control is not clogged or drain line restricted. Be sure water pressure has not dropped and that pump has sufficient capacity</li> <li>G. Increase frequency of regeneration. Make sure there are no leaks in toilets or sinks</li> </ul>
<b>2. Filter fails to regenerate</b>	<ul style="list-style-type: none"> <li>A. Electrical service to unit has been interrupted</li> <li>B. Timer is defective</li> <li>C. Power failure</li> <li>D. Timer motor does not run</li> </ul>	<ul style="list-style-type: none"> <li>A. Assure permanent electrical service (check fuse, plug or switch)</li> <li>B. Replace timer</li> <li>C. Reset time of day</li> <li>D. Replace defective motor</li> </ul>
<b>3. Filter regenerates every day</b>	<ul style="list-style-type: none"> <li>A. Faulty gear train</li> </ul>	<ul style="list-style-type: none"> <li>A. Check unit sizing and programming</li> </ul>
<b>4. Loss of water pressure</b>	<ul style="list-style-type: none"> <li>A. Iron or turbidity build-up in filter</li> <li>B. Filter not regenerating often enough</li> <li>C. Not enough water volume or pressure to backwash properly</li> </ul>	<ul style="list-style-type: none"> <li>A. Clean control and treat bed with Iron Out. Increase frequency of regeneration</li> <li>B. Increase frequency of regeneration</li> <li>C. Correct water supply problem</li> </ul>
<b>5. Loss of media through drain line</b>	<ul style="list-style-type: none"> <li>A. Air in water system</li> <li>B. Backwash rate too fast</li> </ul>	<ul style="list-style-type: none"> <li>A. Assure that well system has proper air eliminator control. Check for dry well condition</li> <li>B. Check drain flow control for proper flow rates</li> </ul>
<b>6. Drain flows continuously</b>	<ul style="list-style-type: none"> <li>A. Foreign material in control</li> <li>B. Timer motor stopped or jammed</li> </ul>	<ul style="list-style-type: none"> <li>A. Remove piston assembly and inspect bore. Remove foreign material and check control in various regeneration positions</li> <li>B. Replace timer motor</li> </ul>

# COMMON SPARE PARTS

Part Number	Description
60090026	Elbow, Inlet/Outlet, 1" NPT Comes with O-Ring
60090027	Straight, Inlet/Outlet, 1" NPT Comes with O-ring
60090040	Elbow, Drain line, 1/2" NPT Comes with O-Ring
60090029	Elbow, Drain line, 3/4" NPT Comes with O-Ring
60090030	Elbow, Drain line, 1" NPT Comes with O-Ring
60090028	Drain Line Hose Barb
60010227	Drain Line Red Clip
92387	Large Red Bypass Clip
60010069	Brine Line Red Clip
60010006	Bypass tool
60010052	Transformer 12 volt
60010382	Problem water injector kit
92360	100% silicone-based lubricant
99003	Media Funnel
92383	Downflow Piston Assembly
60010417	Brine Valve
92382	Seal & Spacer Kit



# WARRANTY

## 89DF Dual Media Tank Residential Water Filter

**NOTICE:** THIS MANUAL CONTAINS A LIMITED WARRANTY. BY INSTALLING AND/OR USING THIS PRODUCT, YOU WAIVE CERTAIN LEGAL RIGHTS INCLUDING THE RIGHT TO SUE OR CLAIM COMPENSATION IN THE EVENT OF PROPERTY DAMAGE, INJURY AND/OR DEATH.

Products manufactured and assembled by Canature WaterGroup™ are warranted to do the work for which they are intended where properly installed, operated and maintained. Canature WaterGroup™ warrants each new residential water filter to be free from defects in materials and workmanship subject to the qualifications or exclusions below.

Residential Systems are defined by pressure tank size and / or the amount of resin or filter media contained in the tank. Residential systems use up to 13" [330 mm] diameter tanks and can contain up to 3.0 cubic feet [28.3 L] of resin or filter media.

### Warranty on Control Valve and Parts:

Canature WaterGroup™ will replace or repair any part (except for Wear and Tear Items – Media, Piston, Seals and Brine Valve) which fails within seven (7) years from date of manufacture, as indicated by the serial number, provided the failure is due to a defect in material or workmanship. The only exception from the date of manufacture shall be proof of purchase or installation is provided and then the warranty period shall be from the date thereof.

### Warranty on Mineral Tanks and Brine Tanks:

Canature WaterGroup™ will provide a replacement mineral tank or brine tank to any original equipment purchaser in possession of a tank that fails within the lifetime of the original owner, provided the failure is due to a defect in material or workmanship and that the water filter or filter is at all times operated in accordance with specifications provided in the Owner's Manual and not subject to freezing or vacuum.

### Exclusions:

Damage to any part of this water filter or filter as a result of misuse, misapplication, neglect, alteration, accident, installation or operation contrary to our printed instructions, damage to ion exchange resin and seals caused by chlorine / chloramines in the water supply, damage to internal pistons and seals caused by wear and tear from iron, manganese, sediment and or silt, or damage caused by any force of nature is not covered in this warranty. At our sole discretion, we will repair or replace defective parts if our warranty department determines it to be defective under the terms of this warranty. Canature WaterGroup™ assumes no responsibility for consequential damage, labor or expense incurred as a result of a defect or failure. Media and Resin coverage is limited to the warranty provided by the original manufacturer.

As a manufacturer, we do not know the characteristics of your water supply. The quality of water supplies may vary seasonably or over a period of time. Your water usage may vary as well. Water characteristics can also change if the appliance is moved to a new location. For these reasons, we assume no liability for the determination of the proper equipment necessary to meet your requirements, and we do not authorize others to assume such obligation for us. Further, we assume no liability and extend no warranties, express or implied, for the use of this product with a non-potable water source or a water source which does not meet the conditions for use as described in the Owners Guide.

CANATURE WATERGROUP'S™ OBLIGATIONS UNDER THIS WARRANTY ARE LIMITED TO THE REPAIR OR REPLACEMENT OF THE FAILED PARTS OF THE WATER SOFTENING SYSTEM AND WE ASSUME NO LIABILITY WHATSOEVER FOR DIRECT, INDIRECT, INCIDENTAL, CONSEQUENTIAL, SPECIAL, GENERAL OR OTHER DAMAGES.

### Return of Goods:

An authorization number must be obtained before returning any merchandise. NOTE: All material returned to Canature Watergroup must be returned freight prepaid. Upon inspection, if our warranty department determines the goods to be defective under the terms of this warranty, the warranty shall be limited to the defective parts to be repaired, replaced, or credited at Canature WaterGroup's discretion. You pay only freight to return defective parts to our factory and local dealer charges, including but not limited to labor charges, travel and transportation expenses, and handling fees.

Some State & Provincial jurisdictions do not allow limitations on how long an implied warranty lasts, so the above limitation may not apply to you. Similarly, some State & Provincial jurisdictions do not allow exclusion of incidental or consequential damages, so the above limitations or exclusions may not apply to you. This warranty gives you specific legal rights, and you may also have other rights, which vary from jurisdiction to jurisdiction. Consult your authorized Dealer for warranty and service information.

**Toll Free: 1-877-288-9888**  
**www.canaturewg.com**